

PROCESSING TECHNOLOGIES

INV-COTM

IN-VESSEL COMPOSTING TECHNOLOGY

TECHNOLOGY PROFILE
Prepared By ORSL



ORGANIC RECYCLING
SYSTEMS LIMITED
CLEANTECH | INNOVATION | ENGINEERING

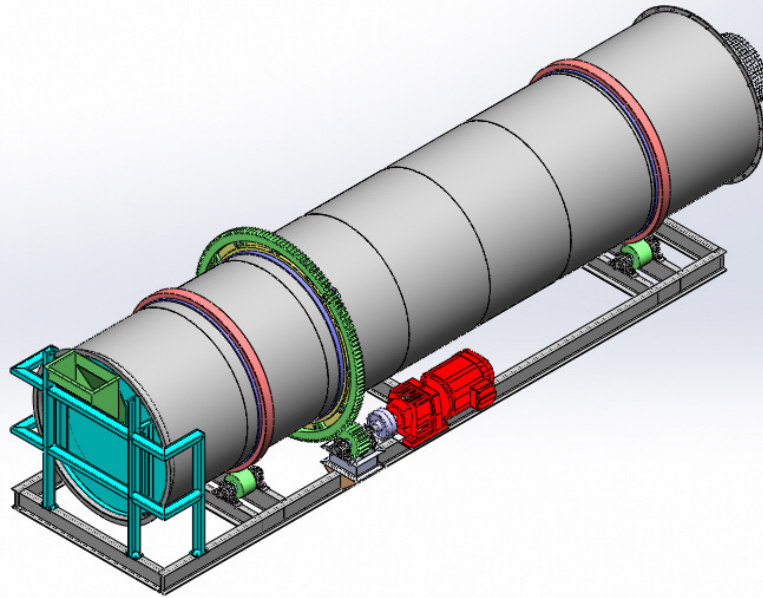

INVESSEL COMPOSTING

- Engineered as per Invesel composting guidelines.
- Lower or nil metal leaching due to pre-segregation and pulverising before composting.
- Temperature control to reduce pathogen impact.
- Works under varying weather conditions.
- Suitable for Unsegregated OFMSW and Segregated organic waste.
- Easy Integration with segregation line and post enhancement system.
- Compost as per Fertiliser control order.
- Suitable for capacities above 10 Tons per day processing.
- Odour free and requires lower footprint.
- Reduced Curing time.