

PROCESSING TECHNOLOGIES

LIPH-ADTM

Liquid Phase Anaerobic digestion

TECHNOLOGY PROFILE
Prepared By ORSL



**ORGANIC RECYCLING
SYSTEMS LIMITED**
CLEANTECH | INNOVATION | ENGINEERING

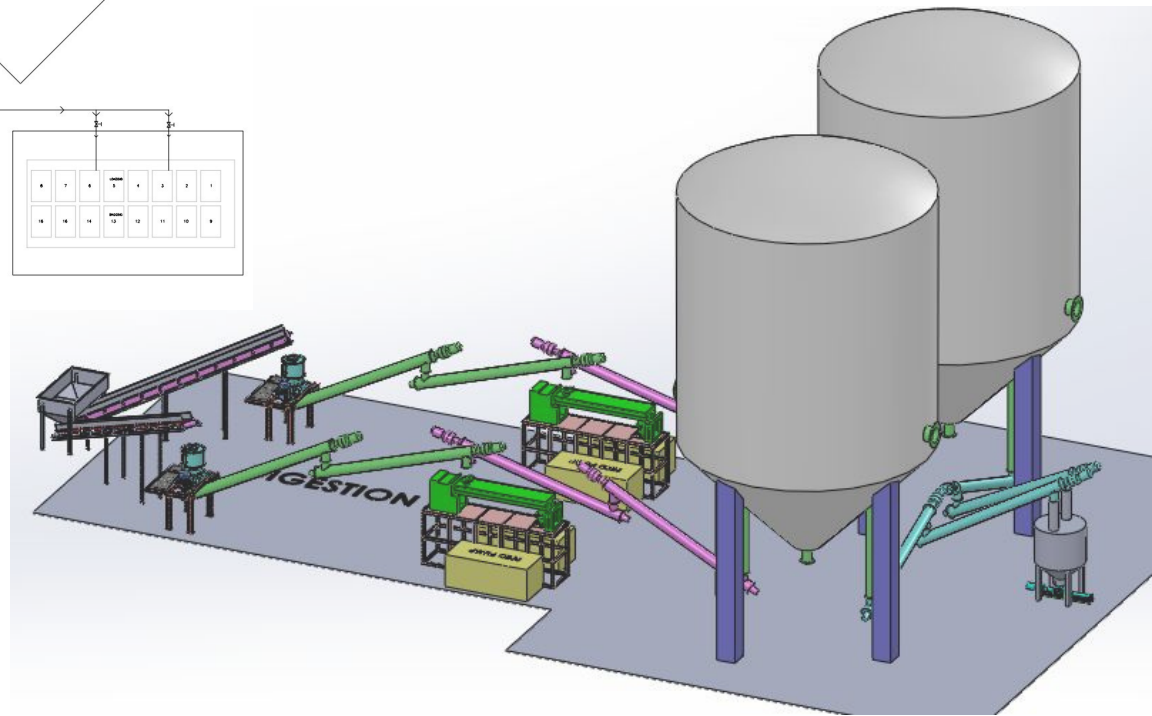
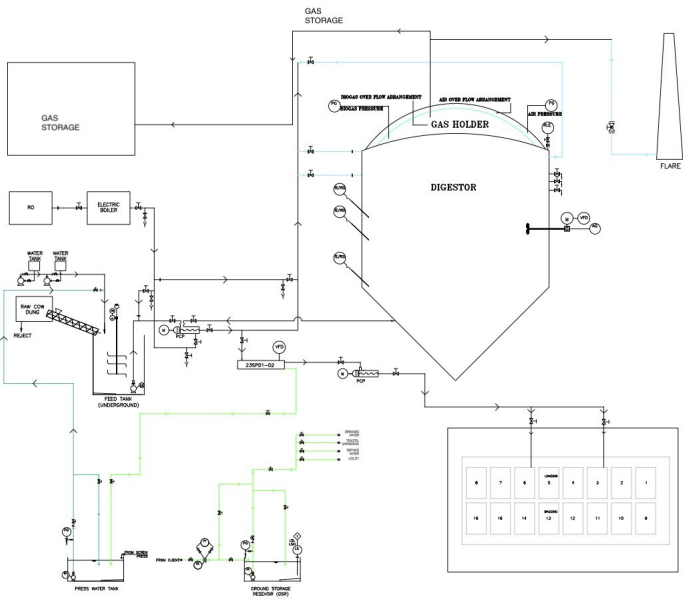

Liquid Phase Anaerobic Digestion

- Low cost solution with easy operation.
- Temperature control digester.
- Works under varying weather conditions.
- Suitable for kitchen waste, press-mud, animal dung, organic fraction with low Total solid content.
- Easy Integration with segregation line and post treatment system.
- Biogas generated can be used for power, vehicular or cooking fuel, heating and refrigeration
- Suitable for capacities below 50 Tons per day processing.